



ESE power generator

TRANSLATION OF THE OPERATING INSTRUCTIONS



ESE 3000 i

Article-No. 110 006

Manufacturer **ENDRESS Elektrogerätebau GmbH**

Neckartenzlinger Str. 39
D-72658 Bempflingen, Germany

Tel: + 49 (0) 71 23 / 9737 - 0

Fax: + 49 (0) 71 23 / 9737 – 50

Email: info@endress-stromerzeuger.de

www: <http://www.endress-stromerzeuger.de>

Document number / version E136085 / i03

Publication date January 2019

Copyright © 2019 ENDRESS Elektrogerätebau GmbH

This documentation and parts thereof are subject to copyright. Any use or modification beyond the restrictions of the Copyright Act is forbidden and subject to penalty without the consent of ENDRESS Elektrogerätebau GmbH.

This applies in particular to copies, translations, microfilming, as well as storage and processing in electronic systems.

Notes on printing All descriptions, technical details and illustrations refer to the version of the generator for printing.

We reserve the right to make modifications in terms of ongoing technical development. This operating manual does not include technical modifications that occurred after printing.

The colours in this operating manual do not always comply completely with the actual designs due to technical printing reasons.

Table of Contents

1	Directories	5
2	About this manual	6
2.1	Using this operating manual	6
3	Product identification	8
3.1	Welcome to ENDRESS!	8
3.2	Your product	8
3.2.1	A device description and intended use	8
3.2.2	Foreseeable misuse	9
3.3	Scope of delivery of your generator	11
3.4	Labels on the generator	12
4	For your safety	14
4.1	Safety symbols	14
4.2	General safety instructions	16
4.3	Residual risks	16
4.4	Authorised operating personnel – qualifications and obligations	21
5	Checking the electrical safety	23
6	Description of the device	24
6.1	Views	24
6.2	Important components of the intake and operation side	25
6.3	Important components of the exhaust and maintenance side	26
6.4	Control panel components	27
7	Commissioning	28
7.1	Transporting and preparing your generator	29
7.2	Refuelling your generator	30
7.3	Starting the generator	31
7.4	Turning off your power generator	33
7.5	Connection of power consuming equipment	34
8	The device in-use	37
8.1	Operation of the ECD 03 multi-functional display	37
8.2	ECOtronic (idle down)	37
9	Maintenance	39
9.1	Maintenance plan	39
9.2	Maintenance work	40
9.3	Engine oil	41
9.3.1	Checking the oil level	41
9.3.2	Changing the engine oil	43
9.4	Maintenance of the air filter	44
9.5	Spark plug maintenance	46
9.6	Starter battery	48
9.6.1	Charging the battery	48
9.6.2	Replacing the battery	49

9.7	Cleaning the spark screen	50
9.8	Cleaning the power generator	51
10	Storage	52
11	Disposal	53
12	Troubleshooting	54
13	Technical data	57
14	Replacement parts	59
	Keyword index	62

1 Directories

1.1 List of illustrations

Fig. 3-1	Example of a type plate	.8
Fig. 3-2	included in delivery	.11
Fig. 3-3	Labels on the device	.12
Fig. 6-1	Views of the generator	.24
Fig. 6-2	Components on the intake and operating side	.25
Fig. 6-3	Components on the exhaust and maintenance side	.26
Fig. 6-4	Components on the control panel	.27
Fig. 7-1	Initial start-up	.28
Fig. 7-2	Refuelling the generator	.30
Fig. 7-3	Operating controls for an electrical and a manual start	.32
Fig. 8-1	ECD 03 multifunction display	.37
Fig. 9-1	Selection of the correct engine oil	.41
Fig. 9-2	Checking and changing engine oil	.42
Fig. 9-3	Oil dipstick	.42
Fig. 9-4	Filling tool	.43
Fig. 9-5	Air filter behind the ventilation grille (removed)	.45
Fig. 9-6	Removing the air filter insert	.46
Fig. 9-7	Remove spark plug	.47
Fig. 9-8	Checking the spark plug	.47
Fig. 9-9	Replacing the starter battery	.49
Fig. 9-10	Spark screen	.50
Fig. 14-1	Spare parts over endressparts.com	.59

1.2 List of tables

Tab. 3-1	Labels on the device	.13
Tab. 5-1	Recommended test intervals	.23
Tab. 9-1	Generator maintenance plan	.40
Tab. 12-1	Troubleshooting	.55
Tab. 13-1	Generator technical data	.58

2 About this manual

Through publication of this operating manual we wish to describe and explain your power generator and its use in the best possible way. In doing so we have oriented ourselves on the latest European standard DIN EN 82079-1 when creating this operating manuals.



NOTICE!

It is absolutely essential for safe and appropriate use that you read through this manual very carefully and understand it before using the device for the first time.

Your observance of it creates the foundation for,

- avoiding dangers for yourself and others,
- reducing repair costs and downtimes as well as
- increasing the reliability and service life of the generator.

Not only this manual but also the laws, regulations, guidelines, and standards applicable in the country of use must be observed.

Safe operation of the power generator as a complete unit is described in this document. You will also find, if necessary, further technical information in the scope of delivery which is binding for the individual components of the device.

2.1 Using this operating manual

In order to increase the legibility, comprehensibility and transparency of the document, certain information is highlighted or identified according a uniform system. The following particularly belong in this category:

signs warning about dangers to life and limb

Safety and warning notices are necessary at all locations where there is potential danger from the device which cannot be eliminated by design or operational measures. We restricted ourselves to the permitted minimum in order to place the required distinctive warning notices at the correct point in time without impairing the legibility and comprehensibility of the operating manual. This is according to the regulations contained in the international standard DIN ISO 3864 describes a fixed rule for all safety and warning notices, as shown in the following example.

Examples:

Signal Word

 **DANGER!**

Hazard Type

Electrical voltage

Hazard Consequence

Risk of suffering potentially deadly electrocution by touching live parts

► Hazard Avoidance

- Only use undamaged connecting lines
- Avoid all damp / wetness when connecting consumers
- Never operate the power generator with an opened control panel

The standard mentioned classifies the safety risks according to different risk potentials. To understand and avoid dangers to one's health and even life, please be sure to read the explanations given in Chapter 4.1 .



Safety symbols

These warning notices are usually used in a safety symbol which also emphasizes the type of danger; see next example. A list of the safety symbols used in this operating manual can be found in Chapter Fig. 3-1 . The safety symbols never stand alone.

Notices on avoidance of damage to the device

According to DIN ISO 3864, notices which warn against false operation and possible damage to the device or to the equipment used should be clearly distinguishable from previously named warning notices in as far there is no danger to health. An example of such a notice can be seen here:

Signal Word

Type and Consequence of Improper Use

▶ Intended Use

NOTICE!

Use of wrong or outdated fuel damages or destroys the engine.

- ▶ Only use released diesel fuel.
- ▶ Observe the shelf life of the fuel according to the supplier.
- ▶ Observe the Operating manual from the engine manufacturer

Symbols and formattings in the text

In order to increase the legibility, comprehensibility and transparency of the document, various information and activities are awarded uniformly repeating bullets or formattings. The following example shows presentation of a sequence of actions with established work steps:

Example:

- ✓ Prerequisites which must be fulfilled before starting any sequence of actions
- 1. Action steps according to a fixed sequence.
- 2. The action steps must be fully completed.
- 3. The sequence must be observed.

Results of the action which should be achieved after performing the sequence of action.



Additional notices for operation or for function of a unit are marked with the adjacent symbol.



NOTICE!

The adjacent symbol is situated anywhere where the supplier documentation must be read and observed and refers to,

- ▶ appropriate information,
- ▶ tasks or
- ▶ action steps.

References to details and components in figures are made with blue bordered position numbers in the text such as the example of CE signs on the type plate demonstrates, see Fig. 3-1 .

3 Product identification

3.1 Welcome to ENDRESS!

We are pleased that you have made the decision to purchase a ENDRESS power generator. You have purchased a high-performance product into which we have embodied decades of our experience and have integrated many functions oriented on daily use. Through careful selection of high quality components and materials in combination with the proverbial Swabian engineering performance you have in your possession a device which will operate reliably for many years, also under the hardest of operating conditions.

3.2 Your product

Customer service

In order to precisely identify your device there is a type plate attached to the power generator (see Fig. 3-3), which includes details about the device designation and serial number "S/N". If you have any questions about device details, functions or notices concerning operation, please contact our

customer service Tel. +49-7123-9737-44

service@endress-stromerzeuger.de

You will find competent contact persons there, also concerning original spare parts and wear parts. (see also Chapter Fig. 14-1)

Type plate

The type plate shown below is a representation of the adhesive label placed on the device. Please be prepared, when contacting our service team, to assist us in exactly identifying your device.





 		ENDRESS Elektrogerätebau GmbH			
		ESE 406 HG-GT Duplex		Neckartenzlinger Straße 39 D-72658 Bempflingen Germany	
		ISO 8528			
Sr/Pr (PRP G1)		4.0kVA/4.0kW	S/N	113552	/ 11
Ur 1~		230V	fr	50Hz	
Ir 1~		17.4A	cos phi	1	
IP(Gen.)		54	nr	3000 min ¹	
hr		100m	Tr	25 °C	
Mfg		Jun.16	m	80 kg	

Fig. 3-1 Example of a type plate

3.2.1 A device description and intended use

Your power generator is a mobile source of power which makes electrical energy available to operate commercially available electrical devices (hereinafter referred to as power consuming equipment) with an AC voltage of 230 V.

The power generator is designed for manual or use with individual electrical power consuming equipment (according to VDE 100, Part 551). The protective conductor assumes the function of the potential equalisation line. A splash-proof protective contact socket with nominal voltage of 230 V / 50 Hz 1~ supplies the power (see Fig. 6-2).

The generator is not to be connected up to other energy distribution systems (e.g. public power supply) or to other energy generation systems (e.g. other generators, solar plant, etc.).

Your generator consists of an inverter alternator which is driven by an internal combustion engine firmly screwed to it. This aggregate unit is mounted elastically with a vibration damper producing few vibrations in a protective and sound dampening housing.

The stability and quality of the generated voltage is achieved electronically by the inverter.

The generator is only to be used outdoors within the indicated voltage, output, and nominal rpm ranges (see type plate).

The generator is not to be used in explosion-prone environments.

The generator is not to be used in environments where there is a risk of fire.

The generator must be operated according to the specifications in the technical documentation.

Every inappropriate use or all activities on the generator which are not described in these instructions is forbidden misuse outside the legally defined limits of liability of the manufacturer.

3.2.2 Foreseeable misuse

Apart from the description of appropriate use, the lawmaker also requires concrete references to the results of “reasonably foreseeable misuse“. In a case of incorrect use or inappropriate handling of the generator the manufacturer's EC Declaration of Conformity, and automatically thereby also the operating licence, are nullified. For products with a manufacturer's warranty the manufacturer will reject any claims made under warranty for damages which were caused by misuse and its direct as well as indirect consequences.

As not authorised Misuse is particularly the case when:

- operation of the generator takes place without valid checks for
 - electrical safety
 - checking that the prescribed servicing and maintenance work has been done
- operation of the generator takes place without the protective equipment installed by the manufacturer
- constructional or electrical modifications of the generator were undertaken
- use of the generator by inadequately instructed operating personnel

Furthermore at all costs avoid the following Misuses:

- Never refuel the generator's own tank when the engine is running. The vibrations and strong exhaust streams during operation can lead to fuel spillage. This leads to an increased risk of explosion and fire and therefore danger to operating personnel, the environment and the device.
- Never refuel the generator's own tank when it is hot. Overflowing fuel and outflowing fuel vapours can ignite on hot parts of the device.
- The generator is never to be connected up to other energy distribution systems (e.g. public power supply) or to other energy generation systems (e.g. other generators, solar plant, etc.). To start with this is usually not permitted by the energy supply company. In both cases this will inevitably lead to severe damage and possibly also severe injury.
- Never place the generator in explosion-prone environments. The individual components of the generator are not designed EX-protected.

- Never operate the generator in rooms, narrow pits or vehicles. The combustion exhaust gases contain poisonous substances including the odourless but deadly gas carbon monoxide (CO) which, when breathed in, can accumulate in cases of poor air circulation to reach deadly concentrations. Also a lack of fresh air circulation leads to overheating and possible damage to the generator right through to destruction.
- For the same reasons of risk, never divert exhaust gases for the purposes of heating rooms or vehicles.
- Never clean the generator with the aid of a high pressure cleaner or a strong jet of water.
- Never allow water to find its way inside the generator. Never pour water over the generator and never clean it using a water hose or a high pressure cleaner.
- Never operate the generator in any area where it could be flooded by high water or any other events. The Protection Class of the device (see Chapter 13) allows operation for spray water, however not in the case of floods.

3.3 Scope of delivery of your generator

Apart from the technical documentation mentioned in Chapter the following articles are Scope of delivery of your generator:

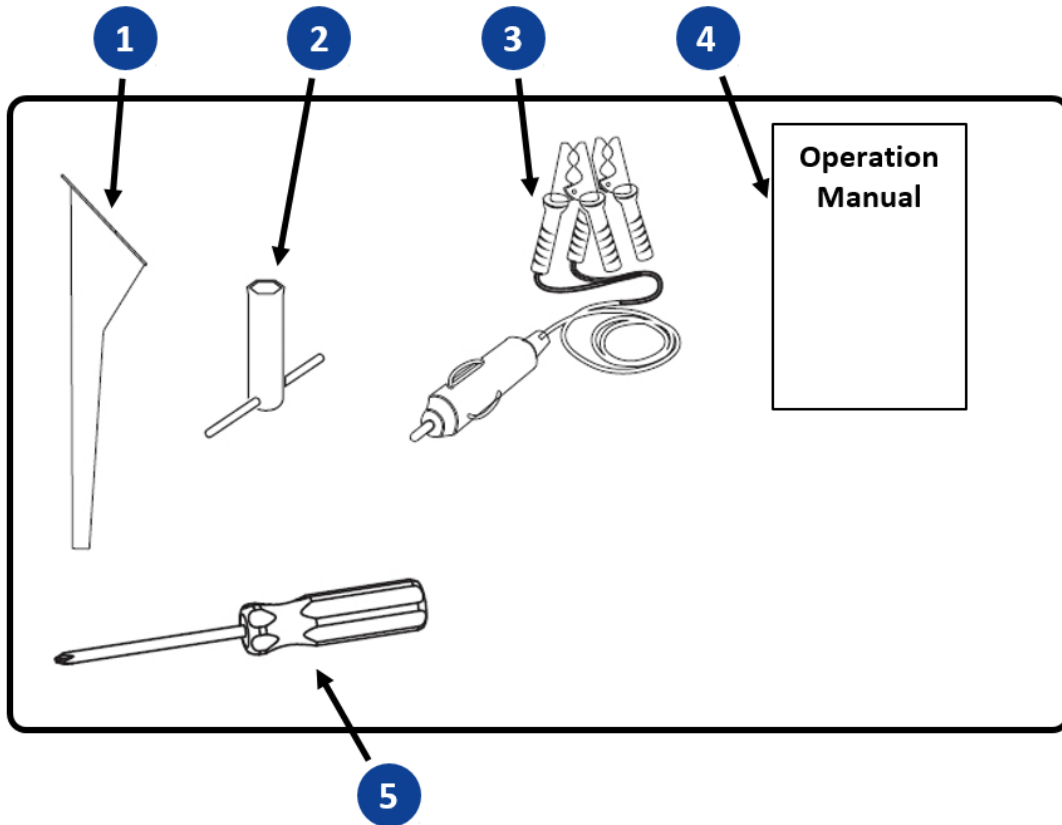

Fig. 3-2 included in delivery

Pos.	Name
①	Filling funnel for changing oil
②	Spark plug wrench
③	Battery charging cable
④	Operating manual and supplier documentation
⑤	Screwdriver









3.4 Labels on the generator

An important part of the operating manual is in the form of labelling and notices on your generator. This The label must not be removed and must always be maintained in a legible condition. In a case of damage to the Labels can be ordered from our customer service team. The following figures and tables show the prescribed attachment point and a short explanation about labels.



Fig. 3-3 Labels on the device

Pos.	Label	Significance																																			
1		Note Fuel quality																																			
2		Note concerning a short operating manual as a memory aid																																			
3	<table border="1"> <tr> <td rowspan="2"> </td> <td colspan="3">ENDRESS Elektrogerätebau GmbH</td> </tr> <tr> <td>ESE 406 HG-GT Duplex</td> <td colspan="2">Neckartenzinger Straße 39 D-72658 Bemtingen Germany</td> </tr> <tr> <td colspan="4">ISO 8528</td> </tr> <tr> <td>Sr/Pr (PRP G1)</td> <td>4.0kVA/4.0kW</td> <td>S/N</td> <td>113552 / 11</td> </tr> <tr> <td>Ur</td> <td>1~ 230V</td> <td>fr</td> <td>50Hz</td> </tr> <tr> <td>Ir</td> <td>1~ 17.4A</td> <td>cos phi</td> <td>1</td> </tr> <tr> <td>IP(Gen.)</td> <td>54</td> <td>nr</td> <td>3000 min¹</td> </tr> <tr> <td>hr</td> <td>100m</td> <td>Tr</td> <td>25 °C</td> </tr> <tr> <td>Mfg</td> <td>Jun.16</td> <td>m</td> <td>80 kg</td> </tr> </table>		ENDRESS Elektrogerätebau GmbH			ESE 406 HG-GT Duplex	Neckartenzinger Straße 39 D-72658 Bemtingen Germany		ISO 8528				Sr/Pr (PRP G1)	4.0kVA/4.0kW	S/N	113552 / 11	Ur	1~ 230V	fr	50Hz	Ir	1~ 17.4A	cos phi	1	IP(Gen.)	54	nr	3000 min ¹	hr	100m	Tr	25 °C	Mfg	Jun.16	m	80 kg	Type plate
	ENDRESS Elektrogerätebau GmbH																																				
	ESE 406 HG-GT Duplex	Neckartenzinger Straße 39 D-72658 Bemtingen Germany																																			
ISO 8528																																					
Sr/Pr (PRP G1)	4.0kVA/4.0kW	S/N	113552 / 11																																		
Ur	1~ 230V	fr	50Hz																																		
Ir	1~ 17.4A	cos phi	1																																		
IP(Gen.)	54	nr	3000 min ¹																																		
hr	100m	Tr	25 °C																																		
Mfg	Jun.16	m	80 kg																																		

Pos.	Label	Significance
4		Hot surfaces! Do not touch while operating
5		Potential equalization (earthing for RCD)
6		Note Noise emissions
7		Poisonous exhaust gases Never operate in rooms or pits!
8		Note No naked flames
9		Maintenance notes for the engine
10		Note concerning oil level checking and the filling amount
11		Note on reading operating manual
12		Warning note concerning a hot surface

Tab. 3-1 Labels on the device

4 For your safety

The following chapter describes basic Safety instructions for safe operation of your generator. Your device is a very high-performance electrical machine which is potentially dangerous when operated if it has not been installed, commissioned, used, serviced and repaired according to the operating manual. If necessary, the operating manual will also include different supplements that depend on the country of use, in addition to the present one.

Operation, use, servicing as well as any work with or on the generator is therefore only permitted by such persons who have read this chapter and have put its provisions into practice!

Concrete warning notices can also be found regarding basic safety instructions further on in this operating manual. These are always placed in an explanatory text immediately before the description of work steps which can be dangerous if the warning notice is not observed. Read the following sections for correct and rapid understanding of these safety and warning notices. They describe their systematic structure as well as the meaning of markings and symbols.

4.1 Safety symbols

The safety symbol indicates graphically that a source of danger exists. We use the internationally valid safety symbols from ISO 7010 for rapid and unique classification of the respective dangerous situation. In the following there is a description of the warning symbols used in this operating manual with an explanation about the respective dangerous situations.



Warning of a general hazard

This warning symbol indicates activities where several causes can lead to risks. The concrete danger must be respectively more clearly specified by further notices.



Warning of a dangerous electrical voltage

This warning symbol indicates activities where the danger of electric shock exists, possibly with lethal consequences.



Warning of potentially explosive materials

This warning symbol indicates activities where the danger of an explosion exists, possibly with lethal consequences.



Warning of toxic substances

This warning symbol indicates activities where a risk of poisoning exists, possibly with lethal consequences.

**Warning of corrosive substances**

This warning symbol indicates activities where a risk of chemical burns to the environment as well as people exists, possibly with lethal consequences.

**Warning of environmentally damaging substances**

This warning symbol indicates activities where a risk of contaminating the environment exists, possibly with catastrophic consequences.

**Warning of hot surfaces**

This warning symbol indicates activities during which there is the danger of burns, possibly with lasting consequences.

**Warning of a suspended load**

This warning symbol indicates activities where the danger of falling loads exists, possibly with lethal consequences.

**Warning of automatically starting machines**

This warning symbol indicates activities where a danger of being injured by self-starting machines exists, possibly with lethal consequences.

4.2 General safety instructions

ENDRESS generators are designed to operate electrical equipment with appropriate power output requirements. Other uses can lead to severe injuries to operating personnel as well as persons nearby. There is also increased risk of damaging the generator as well as further damage to equipment.



DANGER!

Mortal danger due to an electric shock if live parts are touched.

- ▶ Never operate the device if it is in a damaged condition.
- ▶ Never operate the electrical consumers and connecting cable (power consuming equipment) in a damaged condition.
- ▶ Never feed directly into existing networks that are already connected to a power source (e.g. power supplier, solar plant, etc.).
- ▶ Never operate the device with wet hands.

The majority of injuries and damage to equipment can be avoided if all instructions given in this manual and all instructions attached to the device are followed.

The generator must not be modified in any way, also not temporarily. This can lead to a mortal risk to operating and deployed personnel and damage to the generator as well as the consumers being used.

Operating company and Operating personnel may only use the generator according to regulations contained in the whole technical documentation (hereinafter referred to as appropriate use).

Every instance of inappropriate use as well as all activities on the generator which are not described in these instructions are forbidden misuse outside the legally defined limits of liability of the manufacturer. In return all claims for damages and claims made under warranty to ENDRESS-Elektrogerätebau GmbH which are associated with misuse are null and void.

4.3 Residual risks

As a manufacturer of EU-compliant machines, ENDRESS make great efforts to create designs which already eliminate possible risk potentials at the design stage. If this is not possible without significantly impairing the functions of a device, we implement suitable protective measures protect the user from injury.

If there are still some residual risks associated with working with the device, we clearly advise the user about these sources of danger, possible consequences as well as measures to avoid such dangers.

The residual dangers were analyzed and Residual dangers identified during the development and design of your generators by means of a danger analysis according to DIN EN 60204, DIN EN ISO 12100 and DIN EN ISO 8528-13.

References to general sources of danger can be found in chapters 5 and 4.4 . From Chapter 6 one can find concrete warning notices placed before every action step which represents a residual risk.

The exact structure and contents of warning notices are defined in the ISO 3864 series of standards and follow an established identification marking required to immediately be able to estimate the degree of the respective

danger. Exactly impress upon yourself the identification marking of the four different danger levels in order to be able to reliably assess the dangers associated with the individual operating states and action steps when reading the operating manual.



DANGER!

DANGER describes a danger which represents a high level of risk, which can lead to death or severe injuries, when not avoided.

- ▶ The individual points provide instructions and
- ▶ notices as aids to avoid the danger
- ▶ or to reduce the risk to an acceptable level.



WARNING!

WARNING describes a danger which represents a medium level of risk, which can lead to death or severe injuries, when not avoided.

- ▶ The individual points provide instructions and
- ▶ notices as aids to avoid the danger
- ▶ or to reduce the risk to an acceptable level.



CAUTION!

CAUTION describes a danger which represents a low level of risk, which can lead to minor or medium level injuries when not avoided.

- ▶ The individual points provide instructions and
- ▶ notices as aids to avoid the danger
- ▶ or to reduce the risk to an acceptable level.

NOTICE!

ATTENTION! describes a situation or action that might result in damage to equipment and/or malfunctions if it is not prevented.

- ▶ The individual points provide instructions and notices
- ▶ as an aid to avoid or prevent damage to equipment.



DANGER!

Mortal danger due to an electric shock if live parts are touched.

- ▶ Never operate the device if it is in a damaged condition.
- ▶ Never operate the electrical consumers and connecting cable (power consuming equipment) in a damaged condition.
- ▶ Never feed directly into existing networks that are already connected to a power source (e.g. power supplier, solar plant, etc.).
- ▶ Never operate the device with wet hands.



! DANGER!

Engine exhaust gases contain poisonous and partially invisible gases such as carbon monoxide (CO) and carbon dioxide (CO₂).

Risk of death due to poisoning or asphyxiation.

- ▶ Ensure that there is good ventilation during the whole period of operation.
- ▶ Only operate the generator in the open.
- ▶ Never direct the exhaust gases into rooms or pits.



! DANGER!

Danger of severe or mortal injuries being incurred from falling loads.

- ▶ Never stand under or close to a suspended load, also not to provide assistance.
- ▶ Ensure that there is no person in the area of swivel of the lifting device.
- ▶ Use all suitable measures to prevent the suspended load from swaying.



! DANGER!

Leaking engine oil and fuel can burn or explode.

A risk of suffering severe even deadly burns.

- ▶ Prevent engine oil or fuel from leaking out.
- ▶ Remove leaked operating fluids immediately and appropriately.
- ▶ Never use an additional start aid.
- ▶ Smoking, naked flames and sparks are forbidden.



! DANGER!

Hot parts can ignite flammable and explosive materials.

A risk of suffering severe even deadly burns.

- ▶ Never operate the generator in the vicinity of combustible or flammable materials.
- ▶ Never operate the generator in an environment prone to an explosion.



! WARNING!

There is a risk of explosion and fire in the case of inappropriate handling and spark development when working with the battery.

Danger from spraying sulphuric acid. Danger of suffering severe even deadly burns and chemical burns. Danger of being blinded.



- ▶ Never lay electrically conductive parts on the starter battery.
- ▶ Flames, sparks, an open light and smoking are prohibited.
- ▶ Avoid sparks when handling cables and electrical devices, as well as electrostatic discharge.
- ▶ Avoid short-circuits.
- ▶ Wear acid-resistant protective clothing.

**WARNING!**

Escaping corrosive acid fumes or sulphuric acid during and after the charging process. A risk of suffering severe or even deadly burns.

- ▶ Only work with acid-resistant protective equipment.
- ▶ Clean surfaces covered in acid immediately using adequate amounts of water.
- ▶ Only charge the starter battery in a well ventilated environment.

**CAUTION!**

Certain surfaces on the device can get very hot whilst it is running.

Risk of burns

- ▶ Never touch any engine parts (in particular the exhaust system) for a few minutes after ceasing operation.
- ▶ Always leave hot engine parts to cool down before touching them.

**CAUTION!**

A high device weight. Risk of crushing from improper handling during operation or transport.



- ▶ Only lift the generator with the aid of all handles provided or by using a suitable hoist.
- ▶ During transport on vehicles, ensure that there is the prescribed load securing in place.
- ▶ With it in a raised condition, never come close to or stand under the generator.



NOTICE!

Leaking engine oil and operating fluids can contaminate the soil and groundwater.

- ▶ Ensure that the generator is transported horizontally and mounted.
- ▶ Make all efforts, at all costs, to prevent escaping of operating fluids.
- ▶ Dispose of contaminated soil immediately and according to regulations.



NOTICE!

Use of wrong or outdated fuel damages or destroys the engine.

- ▶ Only use the fuel displayed on the sign ([ExternalLink](#):).
- ▶ Observe the possibly enclosed documentation for the fuel release of the engine manufacturer
- ▶ Observe the shelf life of the fuel according to the supplier.
- ▶ Observe the engine operating manual.



NOTICE!

Excessive heat or moisture can destroy the device.

- ▶ Always ensure that there is a good supply of air and heat removal.
- ▶ Never operate the generator in rooms or narrow pits.
- ▶ Never clean the device with the aid of a strong jet of water or high pressure cleaner.
- ▶ Never allow water to find its way inside the generator.

4.4 Authorised operating personnel – qualifications and obligations

Your generators is a complex machine, the operation and maintenance of which requires exact knowledge of its functions and danger potentials. Therefore any work with or on the device, of any kind, may only be performed by authorised and instructed operating personnel.

Quite apart from the authorisation which the operating company of the device must issue, only such persons may operate or service the device who fulfil the following criteria. They are designated in this operating manual as operating personnel.

The authorised operating personnel must:

- be of age.
- be trained in First Aid and be able to provide it.
- be familiar with the accident prevention regulations and safety instructions relevant to the generators and be able to apply them.
- have read Chapter 4 , have understood the contents and are able to use and implement them in practice.
- be trained and instructed according to the rules of conduct in the case of malfunctions.
- have the physical and mental abilities to carry out their responsibilities, tasks, and activities on the generators.
- be trained and instructed in their responsibilities, tasks and activities on the generators.
- have understood the entire technical documentation concerning their responsibilities, tasks and activities on the generators and be able to implement these in practice.

5 Checking the electrical safety

Checking of electrical safety requires different measures to be taken which may only be undertaken by respectively authorised personnel. In doing so the respective, pertinent VDE provisions, EN and DIN standards, in their respectively valid versions, must be observed.

One must, in particular, not use defective or damaged consumers, cable connections and plug connectors (power consuming equipment). There must be checking for an orderly condition at regular intervals (see Tab. 5-1)

Your generator is designed for use with one (1) individual electrical power consuming equipment. Hereby the protective conductor system of the attached power consuming equipment takes over the function of the potential equalization device. The terminal (Fig. 6-4 -9) is connected with this Potential equalization device connected. It is not necessary to earth the generator.

In addition to the details given above, the electrical safety of the generator is to be checked by a qualified electrician at regular intervals. The periods between testing must be established in such a way that the generator and all work equipment to be connected can, according to the general status of knowledge, operational experiences or on the basis of specific evidence, be safe to use in the period between the two inspections. (Examples in TRBS 1201, implementation instructions re §5 of BGV/GUV-V A3, BGI 594, BGI 608, Annex 2, recommendation of BGI/GUV-I 5090 "Repeated testing of mobile electrical equipment").



NOTICE!

The operator is responsible for defining and adhering to the test intervals . Above all one must ensure observance of the respectively valid national regulations.

This responsibility also extends to any additional equipment installed in conjunction with the device.

We recommend the following checks and deadlines as general guideline values:

When	What / how	Who
First start-up at the operating location	<ul style="list-style-type: none"> • See chapter 7 • Visual inspection for externally visible defects such as transport damage. 	Operating personnel
Start-up on a daily basis	<ul style="list-style-type: none"> • See chapter 7.3 • Visual inspection for signs of visible external defects (e.g. damaged insulation, connectors, cable; leaks, noise) 	Operating personnel
Retest at the latest once every six months	<ul style="list-style-type: none"> • According to BGI/GUV-I 5090 "Repeated testing of mobile electrical equipment") • Sample test report according to DGUV information 203-032 *) 	Qualified electrician
*) Download as a text file under → www.dguv.de Webcode: d138299		

Tab. 5-1 Recommended test intervals

6 Description of the device

6.1 Views

The following section provides an overview of the designation and location of the most important components of your generator. It is important to make oneself familiar with these in order to further understand the described functions and operating steps and to be able to perform these safely. Severe or deadly personal injuries can result and/or damage to the generator as well the attached power consuming equipment if these instructions are ignored.

In order to be in a position to clearly re-find named operating controls and components in the following descriptions and instructions, the individual views of the generator are designated throughout in a way which can be taken from the following figure.



Fig. 6-1 Views of the generator

①	Maintenance page	②	Exhaust gas side
③	Control side	④	Suction side

6.2 Important components of the intake and operation side



Fig. 6-2 Components on the intake and operating side

1	Transport grip	2	Tank cover with Tank ventilation
3	Transport grip, retractable	4	Control panel
5	Choke pull	6	Fuel valve
7	Grab handle Cable pull starter	8	Transport wheels
9	Air grille for intake and cooling		

6.3 Important components of the exhaust and maintenance side



Fig. 6-3 Components on the exhaust and maintenance side

1	Transport grip, retractable	2	Transport grip,
3	Exhaust gas outlet	4	Feet
5	Maintenance flap	6	Oil filling screw with Oil dipstick
7	Oil drain screw	8	Spark plug connector
9	Engine air filter		

6.4 Control panel components



Fig. 6-4 Components on the control panel

1	ECO-mode economy circuit	2	Engine starter switch
3	Operating status indicator	4	Schuko socket for 230 V / 16 A / 1~
5	Safety switch for external battery charging	6	Battery charge socket for 12V / 8A DC
7	USB charge socket with an indicator light	8	Multi-functional display
9	Connection for Potential equalisation device	10	Schuko socket for 230V / 16A / 1~ IP68**
11	Warning lights for a low oil level	12	Warning lights for an overload
13	Operational indicator light		

* For similar lead /acid batteries only

**optional

7 Commissioning

The following chapter describes the basic procedure for first time or repeated putting into operation of the generator. Follow the working steps described below when you put your generator into operation for the first time or restart it again after transporting it.



NOTICE!

For start-up and operation of a generator on building and assembly sites, Deutsche Gesetzliche Unfallversicherung (DGUV) in DGUV Information 203-032, the May 2016 edition, requires observance of special protective measures and behaviour regulations.

We also urgently advise observance of relevant DGUV information under comparable operating conditions.

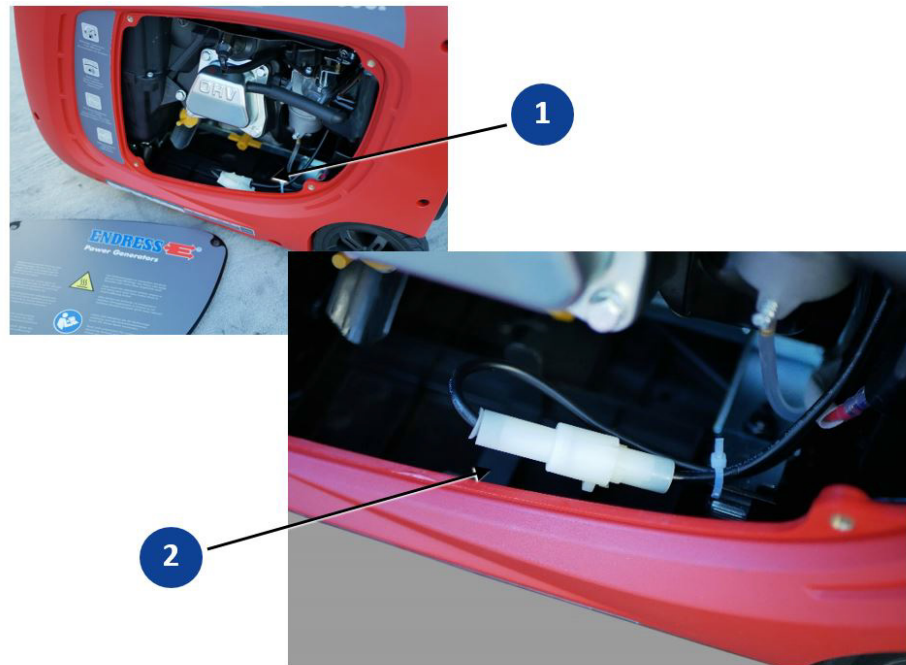

Fig. 7-1 Initial start-up

You must carry out the following preparatory steps after you have unpacked your generator from the delivery packaging and are going to run it for the first time:

Requirements

- ✓ The generator must be fully unpacked.
 - ✓ Suitable engine oil must be ready for use (see Chapter 9.3.1).
 - ✓ Suitable fuel must be ready for use (see Chapter 7.3).
1. Undo the bolts in the engine's side maintenance cover (2) and then open it.
 2. Remove the cable tie from the 12V cable (1).
 3. Plug the plug and coupling together (see (3)), to make the power supply from the starter battery.
 4. Fill the engine with the suitable engine oil (see Chapter 9.3).

The generator is now ready to be started.

7.1 Transporting and preparing your generator

The following requirements must be fulfilled before you can transport the generator:

Requirements

- ✓ The installation area must have an even and load carrying substrate
- ✓ The generator must be turned off
- ✓ The generator is cooled down
- ✓ The fuel valve is in the "0" position
- ✓ The tank ventilation valve is in the „OFF“ position.
- ✓ Two persons are available carry the load



WARNING!

Danger due to a high device weight.

Risk of crushing through sliding or a falling down machine

- ▶ Observe the empty weight from to 41 kg.
- ▶ Only carry the device using two persons.
- ▶ Only lift the device using the carrying handles.
- ▶ Raise/lower device evenly.
- ▶ Walk slowly.



NOTICE!

Leaking engine oil and operating fluids can contaminate the soil and groundwater.

- ▶ Ensure that the generator is transported horizontally and mounted.
- ▶ Make all efforts, at all costs, to prevent escaping of operating fluids.
- ▶ Dispose of contaminated soil immediately and according to regulations.

Roll the generator

1. Fold down the mobile Carrying handle fully out.
2. Lift the generator using this handle in order to roll it to the place of use.
3. Lower the device evenly.
4. Fold in the carrying handle fully

The generator has been transported to its place of use and installed.

Carrying the generator

The generator is fitted with a second, fixed carrying handle so that you can lift it up or carry it over rough terrain. Always get a second person to help you.

1. Take hold of the generator together at the unfolded and the fixed carrying handle.
2. Raise the generator evenly.
3. Carry the generator to the place of use.
4. Lower the device slowly and evenly.

The generator has been transported to its place of use and installed.

7.2 Refuelling your generator

Requirements

Proceed as follows to the generator.

- ✓ The generator must be turned off
- ✓ The generator has cooled down
- ✓ There must be an adequate air supply and air removal
- ✓ All power consuming equipment must be disconnected or switched off



DANGER!

Leaking engine oil and fuel can burn or explode.

A risk of suffering severe even deadly burns.

- ▶ Prevent engine oil or fuel from leaking out.
- ▶ Remove leaked operating fluids immediately and appropriately.
- ▶ Never use an additional start aid.
- ▶ Smoking, naked flames and sparks are forbidden.



NOTICE!

Leaking fuel can contaminate soil and groundwater.

- ▶ Take note of the residual quantity in the tank and its maximum filling capacity.
- ▶ Always bear in mind that the fuel gauge reacts only after a time delay.
- ▶ Fill the tank to a maximum of 95%.
- ▶ Always use a filling aid (e.g. funnel).



NOTICE!

Use of wrong or outdated fuel damages or destroys the engine.

- ▶ Only use the fuel displayed on the sign ([ExternalLink:](#)).
- ▶ Observe the possibly enclosed documentation for the fuel release of the engine manufacturer
- ▶ Observe the shelf life of the fuel according to the supplier.
- ▶ Observe the engine operating manual.



1



2

Fig. 7-2 Refuelling the generator

Refuelling the generator

1. Put the fuel valve **1** in position "0".
2. Unscrew the tank cover (Fig. 6-2 **2**).
3. Insert filler aid into the filler neck.
4. Fill with fuel slowly and evenly.
5. Fill the tank to the maximum at the red bar **2** in order not to overfill the tank.
6. Remove the filler aid.
7. Attach the tank cover again.

The generator is refuelled.

7.3 Starting the generator

Your generators is fitted with an electrical starter as a standard item so you can start it just by pressing the start button. The manual start function also allows manual starting, for example when the starter battery is discharged. Both methods are described below.

Proceed as follows to start the generator electrically:

Requirements

- ✓ electrical safety has been checked (see chapter.5).
- ✓ the fuel tank is sufficiently full.
- ✓ the daily operating checks were made (see 9).
- ✓ there is an adequate air supply and air removal.
- ✓ if necessary the existing exhaust hose (special accessory) is attached.
- ✓ all power consuming equipment is disconnected or switched off.



DANGER!

Leaking engine oil and fuel can burn or explode.

A risk of suffering severe even deadly burns.

- ▶ Prevent engine oil or fuel from leaking out.
- ▶ Remove leaked operating fluids immediately and appropriately.
- ▶ Never use an additional start aid.
- ▶ Smoking, naked flames and sparks are forbidden.



DANGER!

Engine exhaust gases contain poisonous and partially invisible gases such as carbon monoxide (CO) and carbon dioxide (CO₂).

Risk of death due to poisoning or asphyxiation.

- ▶ Ensure that there is good ventilation during the whole period of operation.
- ▶ Only operate the generator in the open.
- ▶ Never direct the exhaust gases into rooms or pits.

NOTICE!

Your generators will be delivered without any engine oil in it.

- ▶ You must fill the engine with engine oil before using it for the first time as described in Chapter 9.3.2 .

Electrical start

1. Turn the tank ventilation valve on the tank cover Fig. 6-2 ② into the "ON" position.
2. Open the fuel valve by turning the rotary knob ② into the "I" position.
3. Pull the choke lever ③ fully for a cold engine, somewhat less for a hot engine.
4. Press and hold down the engine start switch ⑤ in position "II".
The engine starts.
The green operation indicator light ⑦ lights up.
5. Release the engine start switch ⑤ .
6. Push the choke lever ③ back in again slowly. If the engine begins to run unevenly, pull out the choke lever out a little ③ for a short time and repeat the process.

The motor runs at a stable speed.

You can connect to one piece of power consuming equipment.

You can use ECO mode (see Chapter 8.2 .



NOTICE!

Only activate the starter briefly (max. 5-10 seconds). Never start or run the engine with the battery disconnected.

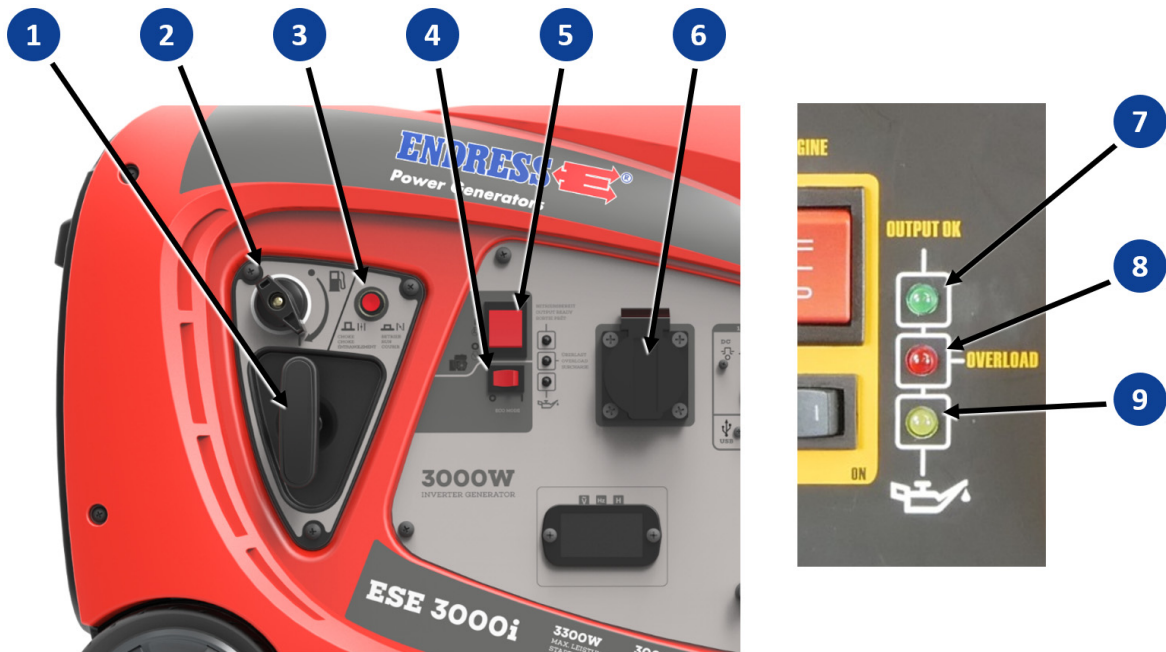

Fig. 7-3 Operating controls for an electrical and a manual start

A hand start

1. Turn the tank ventilation valve Fig. 6-2 **2** to the position “ON“ on the tank cover.
2. Open the fuel valve by turning the rotary knob **2** into the “I“ position.
3. Pull the choke lever **3** fully for a cold engine, somewhat less for a hot engine.
4. Move the engine start switch **5** into the “I“ position.
5. Support yourself with one hand or a foot on the device and pull strongly on the grab handle **1** of the cable pull starter/
The engine starts.
6. Do not just release the grab handle **1** but instead lead it carefully back into the generator.
*The green operation indicator light **7** lights up.*
7. Push the choke lever **3** back in again slowly. If the engine begins to run unevenly, pull out the choke lever out a little **3** for a short time and repeat the process.
The motor runs at a stable speed.
You can connect to one piece of power consuming equipment.
You can use ECO mode (see Chapter 8.2).



NOTICE!

Do not apply load to the generator immediately after a cold start.

- ▶ Allow the generator engine to warm up for a few minutes before switching on a load when the generator has not been operating for more than eight hours (or for very low external temperatures).

7.4 Turning off your power generator

Proceed as follows to switch off your generator:

Requirements

- ✓ the attached power consuming equipment is disconnected or switched off.



CAUTION!

Certain surfaces on the device can get very hot whilst it is running.

Risk of burns

- ▶ Never touch any engine parts (in particular the exhaust system) for a few minutes after ceasing operation.
- ▶ Always leave hot engine parts to cool down before touching them.

Switching the generator off

1. Continue to run the engine without load for about two minutes.
2. Move the engine start switch Fig. 7-3 - **5** into position “0“.
The engine comes to a standstill and the generator is switched off.
3. Turn the rotary knob on the fuel valve Fig. 7-3 - **2** back into position “0“.
The generator is switched off and secured.



! DANGER!

Explosion hazard due to escaping fuel or fuel vapours.

A risk of suffering severe even deadly burns.

- ▶ After stopping the generator, close the fuel valve (fuel feed) as soon as possible.
- ▶ Close the fuel valve (fuel feed) at the latest after ceasing to use the device. **BEFORE** transport.

7.5 Connection of power consuming equipment



! DANGER!

Mortal danger due to an electric shock if live parts are touched.

- ▶ Never operate the device if it is in a damaged condition.
- ▶ Never operate the electrical consumers and connecting cable (power consuming equipment) in a damaged condition.
- ▶ Never feed directly into existing networks that are already connected to a power source (e.g. power supplier, solar plant, etc.).
- ▶ Never operate the device with wet hands.

Proceed as follows to connect one piece of power consuming equipment your generator:

Requirements

- ✓ The generator is started and brought up to operating temperature (see Chapter 7.3)
- ✓ All power consuming equipment is disconnected or switched off.

Connect up to consumers

1. Fold up the spray connection on the Schuko socket 7.3 **6** on the control panel.
2. Insert the plug from the power consuming equipment that is to be connected up all the way into the socket until it stops.

The power consuming equipment is connected to the generator and ready to use.



NOTICE!

When selecting power consuming equipment to supply, do not exceed the maximum power output of the generator of 3,000 W (3,330 W for short time).

Take note of the fact that certain power consuming equipment (e.g. circular saws, blowers, etc.) can significantly exceed their nominal output during an increased start up current when starting. Details can be found in the power consuming equipment's operating manual.

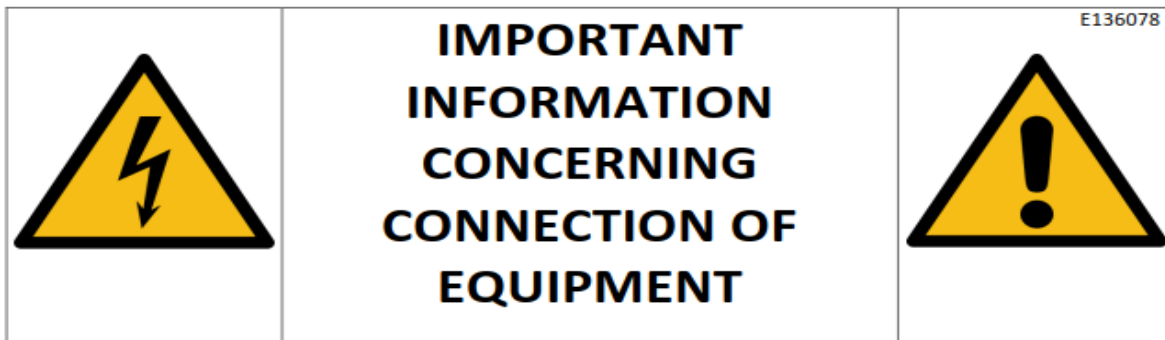

Your generator is designed for mobile use and according to the protective measure

**protective separation with equipotential bonding
according to DIN VDE 0100-551:2017-02 (H 60364-5-551 + A11:2016-05)**

. This differentiates between commissioning undertaken by a trained electrician and that undertaken by an (electrically) untrained person. There are two options for use for the electrically untrained person:

1. connection of a single piece of equipment to the generator

In this case it is not necessary to check the electrical safety (see Chapter “Electrical safety“ in the operating instructions) beyond the protective measures. The protective conductor of the ground contact socket assumes the function of the potential equalisation line. **This case expressly excludes use of a power distributor (multiple socket).**

2. connection of one or more pieces of equipment to the generator

In this case the above-mentioned standard requires one of the following additional protective measures:

- a) protective separation with an insulation monitoring device (IMD) and automatic shut-off
- b) protective separation with residual current protective (RCD) and automatic shut-off

In doing so one RCD or PRCD must be used per power socket or circuit. For 3-phase networks we recommend use of an RCD Type B.

<p>Publication date December 2017</p>		<p>Responsible person HWB</p>
---	--	-----------------------------------

8 The device in-use

8.1 Operation of the ECD 03 multi-functional display

The control displays allow one to display the various operating states of the generator. The display starts automatically as soon as the generator has started.



Fig. 8-1 ECD 03 multifunction display

1. After starting the generator the currently applied voltage appears in the display, ① displayed by the light point next to the “V~” symbol for Volts.
2. One-time pressing of the button ② causes the current frequency to be displayed by the light point next to the “Hz” symbol for Hertz.

The display has been switched over to Frequency.

1. Further pressing of the button ② causes the operating hours to be displayed by the light point next to the “h” symbol for hours (see Fig. Fig. 8-1).

The display has been switched over to Operating hours.

1. Further pressing of the button ② causes the voltage to be displayed in Volts and the sequence begins from the beginning.

The display has been switched over to Volts.

8.2 ECOtronic (idle down)

Your generators is fitted with an ECOtronic function. Fuel consumption and emissions will be reduced when the ECO mode is activated, as the engine speed is automatically adjusted to match the power requirement of the connected consumer. This also leads to a reduction in the noise level. As the power requirement increases, the engine speed will also increase to the same extent and this ensures trouble-free operation of the connected consumer. The electronics raise the engine speed again as soon as the connected power consuming equipment is switched on in order to make the full output available.

NOTICE!

Always switch the ECOtronic off before you operate a very powerful consumer. The engine speed will increase up to nominal speed and provide full power without any delay when you turn on the consumer.

Proceed as follows to run your generators in ECO mode:

Requirements

- ✓ Generator is ready for operation
- ✓ The generator is started (see Chapter Fig. 7-3)

**Switching on
ECOtronic**

Switch the idle engine speed reduction as follows:

1. Bring the rocker switch Fig. 7-3  into the "I" (ON) position.

Idle down is activated. The engine speed will drop significantly when a consumer is being run at a low power or is switched off.

**Turning off
ECOtronic**

Switch the idle down off as follows:

1. Bring the rocker switch Fig. 7-3  into "0" (OFF) position.

Idle down is switched off. The drive motor's speed increases to nominal speed (see Chapter 13 Technical data).

9 Maintenance

generators maintenance is described in this section. It may only be performed by qualified specialist personnel.

Maintenance and repair which is neither described in this operating manual nor in the possibly also delivered operating and maintenance instructions may only be undertaken by authorized service personnel from the manufacturer.

9.1 Maintenance plan

Maintenance work on your generator must be performed periodically in order to secure its readiness to use and reliability over a long period. Only have this work performed by trained specialist personnel. Contact your dealer or our

service hotline +49 (0) 7123 9737-44

service@endress-stromerzeuger.de



NOTICE!

Please note that, in the case of a concluded warranty agreement, you will lose all rights to make claims if your generator is not serviced according to manufacturer regulations.

You can find an overview of the time plan and scope of the required maintenance work in the following maintenance schedule.

Maintenance work		Maintenance interval according to time or operating hours [h]			
Item	Maintenance step	Every 8 h /daily	every 3 months or 25h	every 6 months or 50h	annual-ly every 100 h
Electrical safety	Check	X			
Engine oil	Check fill level	X			
	Change		X		X
Air filter	Cleaning; change when necessary			X	
Fuel tank and fuel filter	Cleaning; change when necessary				X
Fuel lines	Check for cracks and damage; replace if necessary	X			
Spark plug	Check the electrode gap, clean; change when necessary				X
Maintenance work should be performed by your service partner.					

Maintenance work		Maintenance interval according to time or operating hours [h]			
Item	Maintenance step	Every 8 h /daily	every 3 months or 25h	every 6 months or 50h	annual-ly every 100 h
Exhaust system	Check for leaktightness, fasten, if necessary, change seals	X			
	Check the spark screen, clean; change when necessary				X
Carburettor	Check the choke function	X			
Cable pull starter	Check the cable pull and function	X			
Fastening and threaded joints	Check for a fixed hold and damage; replace if necessary				X
Maintenance work should be performed by your service partner.					

Tab. 9-1 Generator maintenance plan

9.2 Maintenance work

Only authorised specialist personnel are allowed to carry out maintenance tasks. Execute all of the maintenance steps in the maintenance schedule according to the following instructions.



CAUTION!

Certain surfaces on the device can get very hot whilst it is running.

Risk of burns

- ▶ Never touch any engine parts (in particular the exhaust system) for a few minutes after ceasing operation.
- ▶ Always leave hot engine parts to cool down before touching them.



NOTICE!

Also always read about the checking and maintenance work which concerns the electrical safety of the generators in the chapter “Checking the electrical safety”.

Disconnect the negative pole of the starter battery in order prevent unintentional restarting of the engine whilst working on it (see Chapter 9.6.2).

9.3 Engine oil

The drive motor for your generator, like every internal combustion engine, requires the required engine oil for cooling and inner cooling. It is also important to use the correct oil, both for refilling and changing oil, and to observe the prescribed maintenance intervals.

To refill and when changing oil, use a commercially available multigrade oil with a viscosity of 10W-30 for four stroke engines as also used in automobile engines. This applies for use of a generator in temperate climates. At very low or very high outside temperatures it may well be necessary to use an engine oil of another viscosity. Please take more precise information from the following info. graphic.

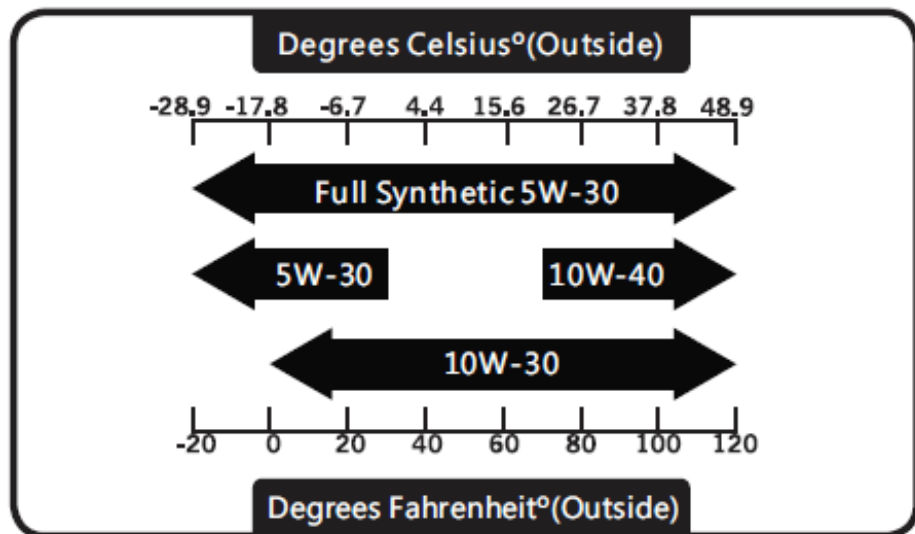



Fig. 9-1 Selection of the correct engine oil

9.3.1 Checking the oil level

Your generator is fitted with an oil lack automatic switching off system to avoid engine damage occurring due to a low engine level. It has two functions:

- 1) it prevents the engine from starting for an inadequate engine oil level
- 2) it switches off the drive motor when the engine oil level falls below the minimum value while operating.

If the automatic switch-off has detected a lack of oil, this is displayed by lighting up of the yellow Fig. 7-3  warning light. In order to avoid delays and interruptions during operation, check the engine oil level before every putting into operation.

Requirements

Ensure that the following prerequisites are met before you check:

- ✓ Ensure that the generator is mounted horizontally.
- ✓ Wait after previous operation for about five minutes before checking until the engine oil has gathered again in the oil sump to obtain a correct measurement.



CAUTION!

The engine and operating equipment on the generator can get very hot while running.

Risk of burns

- ▶ Never touch any engine parts (in particular the exhaust system) for a few minutes after ceasing operation.
- ▶ Allow the engine to cool off for at least five minutes before changing or checking the engine oil.

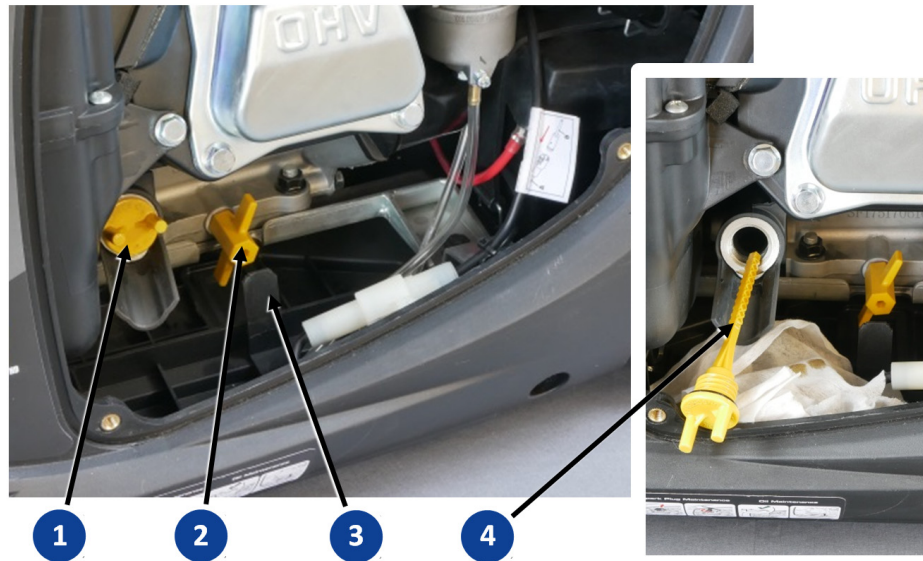

Fig. 9-2 Checking and changing engine oil

Checking the oil level

1. Loosen the four screws on the maintenance flap Fig. 6-3 ④ and remove the maintenance flap.
2. Loosen the yellow screw plug ① and remove it from the filling opening. CAUTION! The oil dipstick attached to the screw is wetted with oil.
3. Read off the oil level on the ④ oil dipstick. This should not be below the middle between the “L” and “H” markings and never above the “H” marking.

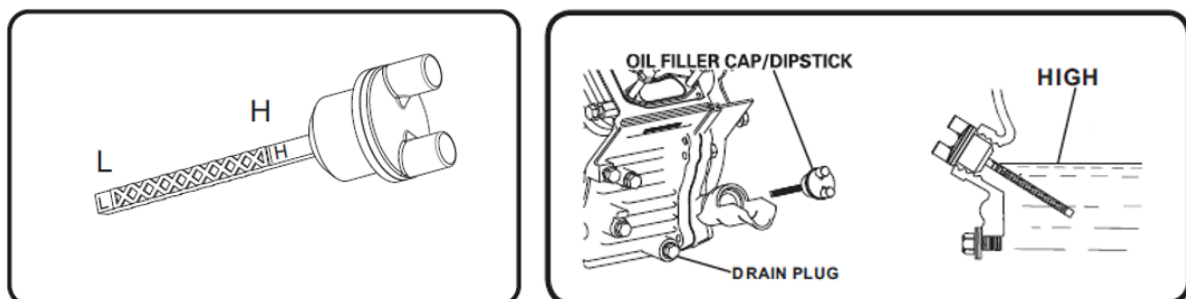

Fig. 9-3 Oil dipstick

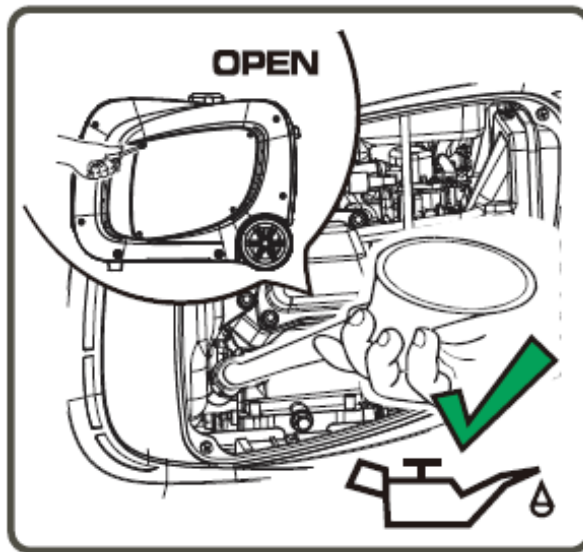

Fig. 9-4 Filling tool

Refill engine oil

If the oil level is too low, instigate the next steps to correct the level.

1. Make ready the engine oil to top up with.
2. Lead the filling funnel also supplied into the previously opened filling opening of the engine (see Fig. Fig. 9-4).
3. Just put a small amount of engine oil in the funnel and wait until the oil has drained down completely.
4. Remove the filling funnel.
5. Compare the oil level with picture Fig. 9-3 (at the bottom right) and repeat steps 2 to 4 until the engine oil has reached the edge of the filling opening.
6. Clean the oil dipstick with a clean cloth and turn it clockwise all the way into the filling opening.

The oil level has been checked and topped up.

9.3.2 Changing the engine oil

The engine oil in your generator need changing after the first 25 operating hours, at the latest however after three months, to remove all of the abrasion material produced during the run-in phase. There should subsequently be an oil change every 100 operating hours, at the latest however annually (see Maintenance schedule Tab. 9-1).



CAUTION!

The engine and operating equipment on the generator can get very hot while running.

Risk of burns

- ▶ Never touch any engine parts (in particular the exhaust system) for a few minutes after ceasing operation.
- ▶ Allow the engine to cool off for at least five minutes before changing or checking the engine oil.

Requirements

Ensure that the following prerequisites are met before you change the engine oil:

- ✓ Place the generator in such a way that a suitable catching pan can be placed under the oil drain screw.
- ✓ Ensure that the generator is mounted horizontally.
- ✓ Wait after previous operation for at least five minutes before changing the oil to allow the oil to flow into the oil sump and for the engine oil to cool off.



NOTICE!

Leaking engine oil contaminates the soil and groundwater.

- ▶ Use a suitable oil catching receptacle.
- ▶ Old oil is a special waste and may only be disposed of over suitably qualified collection points.

Draining off old oil

1. Loosen the four screws on the maintenance flap Fig. 6-3 **4** and remove the maintenance flap.
2. Place a suitable oil collection container under the generator.
3. Loosen the yellow screw plug Fig. 9-2 **1** and remove it from the filling opening. CAUTION! The oil dipstick attached to the screw is wetted with oil.
4. Open the cover Fig. 9-2 **3** and ensure that the collection container is placed correctly.
5. Remove the oil drain screw. Fig. 9-2 **2**.

The old oil flows through the housing opening into the collection container.

6. If the old oil has completely drained out, close the opening using a new oil drain screw.
7. Dispose of the old oil according to regulations.

The old oil is drained off.

Refilling with fresh engine oil

1. To refill with fresh engine oil, proceed as described in Chapter Fig. 9-2 . Observe the instructions to select a suitable oil. The amount of oil needed is 0.6 litres.
2. Close the cover Fig. 9-2 **3** again carefully.
3. Attach the maintenance flap Fig. 6-3 **4** again using four screws.

The engine oil has been changed. Your generator is ready to use again.

9.4 Maintenance of the air filter

The air filter insert must be cleaned every 50 operating hours and also changed if necessary. Operation with a dirty filter increases fuel consumption, pollutant emissions and engine wear. A damaged or missing air filter can destroy the engine.

Proceed as follows to service the air filter.

Requirements

- ✓ The generator is switched off.
- ✓ The engine is cooled down sufficiently.
- ✓ A new air filter insert is ready to use.

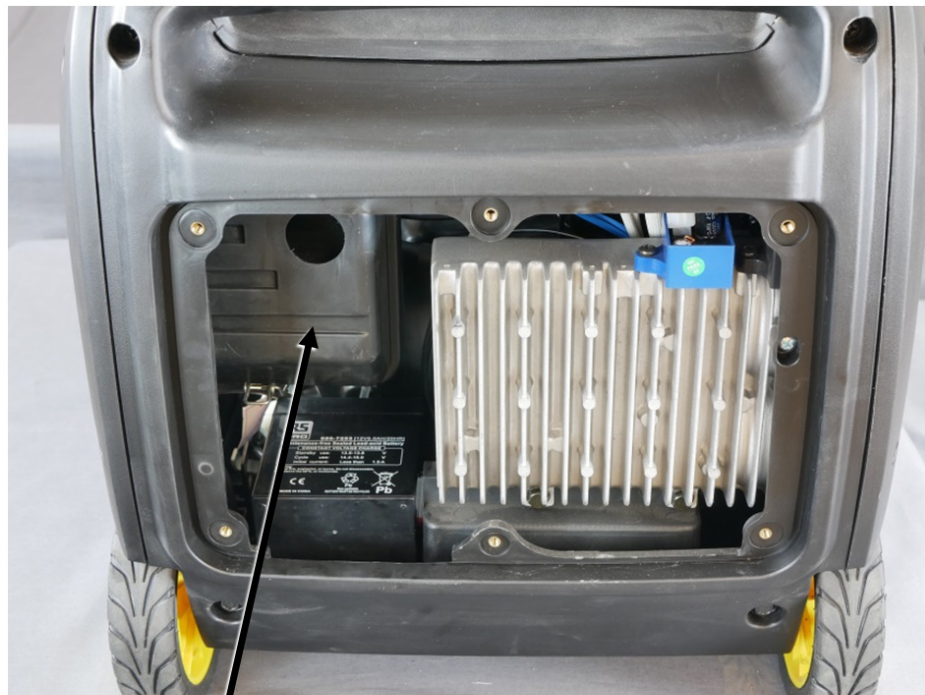

1

Fig. 9-5 Air filter behind the ventilation grille (removed)

Change the air filter insert

1. Loosen the six screws to remove the ventilation grille Fig. 6-2 **9** and to make the air filter housing Fig. 9-5 **1** accessible.
 2. Open both fastening clamps Fig. 9-6 - **1** and pull off the air filter cover Fig. 9-6 **3**.
 3. Remove the air filter insert Fig. 9-6 - **2** and decide after the assessment:
 - a) in a case of minor soiling remove loose dirt particles from the air filter insert.
 - b) in a case of strong soiling use a new air filter insert.
 4. Clean the air filter housing and cover, in this case in particular the suction opening.
 5. Protect your hands from contact with engine oil.
 6. Apply a few drops of new engine oil to the cleaned or new air filter insert.
 7. Knead the air filter insert in order to distribute the oil evenly into the foam.
 8. Wring out the air filter insert strongly afterwards to remove excessive oil.
 9. Insert the air filter insert into the air filter housing.
 10. Carefully place the air filter cover **3** on the air filter housing and fasten it on using the clamps **1**.
 11. Insert the ventilation grille Fig. 6-2 **9** again and fasten using six screws.
 12. Dispose of a soiled air filter insert according to regulations.
- Maintenance of the air filter is complete.*

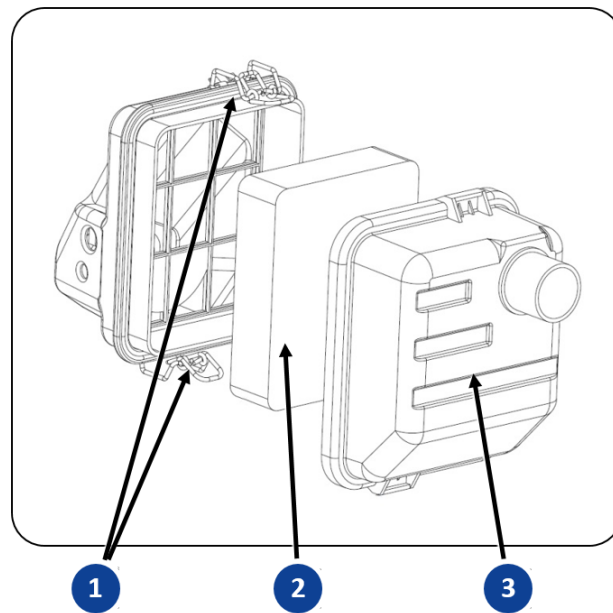

Fig. 9-6 Removing the air filter insert

9.5 Spark plug maintenance

The spark plug must be checked every 100 operating hours, at least however once a year, and replaced if necessary. Wrong adjusted, soiled or worn spark plugs can have a negative effect on the starting behaviour, engine running, fuel consumption and pollutant emissions.



NOTICE!

When replacing the spark plug, only use the following types:

- ▶ TORCH F6RTC
- ▶ NGK BPR6ES
- ▶ CHAMPION RN9YC

Proceed as follows to perform spark plug servicing.

Requirements

- ✓ The generator must be turned off
- ✓ The engine is cooled down sufficiently.
- ✓ A new spark plug is ready to use.

One has the required tool

- A spark plug wrench (in the scope of delivery)
- Setting gauge for the electrode gap

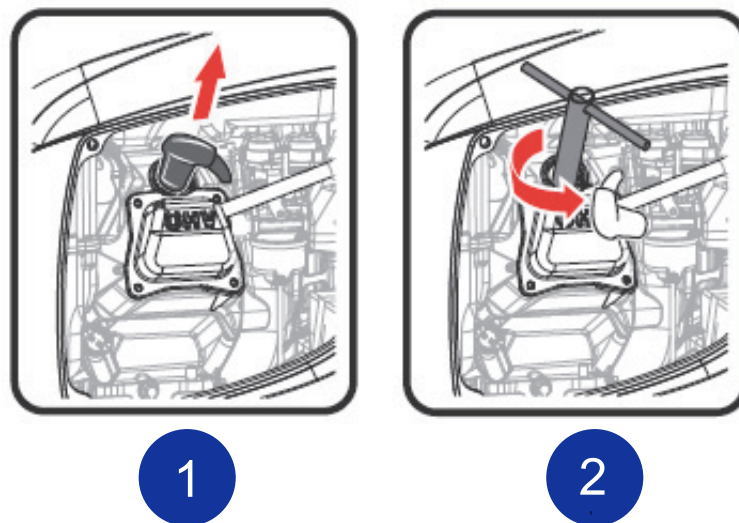

Fig. 9-7 Remove spark plug

- Remove spark plug**
1. Loosen the four screws on the maintenance flap Fig. 6-3 **4** and remove the maintenance flap.
 2. Pull the spark plug connector Fig. 9-7 - **1** of the spark plug. To do this always pull directly on the plug, never on the ignition cable!
 3. Place the spark plug wrench on the spark plug Fig. 9-7 - **2** and loosen this by turning anti-clockwise.

The spark plug is removed and must now be assessed.

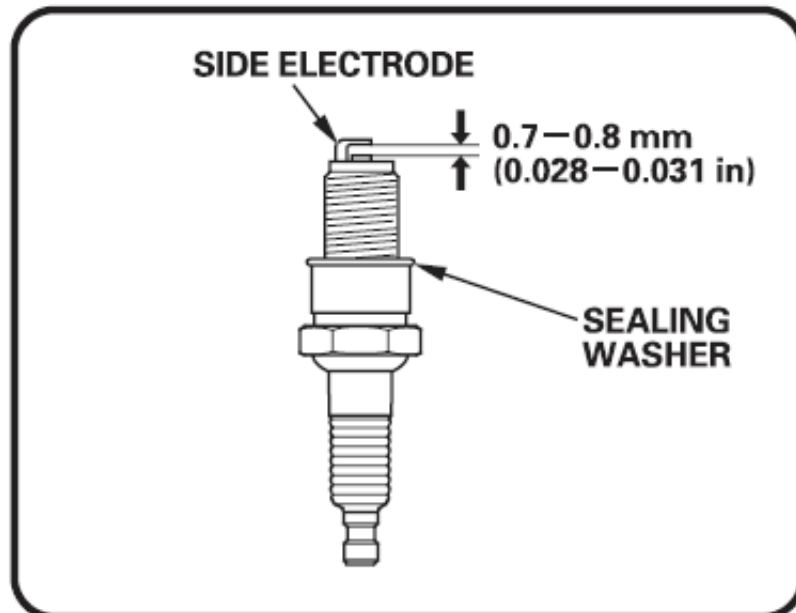

Fig. 9-8 Checking the spark plug

- Checking the spark plug**
1. Check the spark plug for damage and clean it using a suitable brush, if it can be used again.
 2. Check the condition and gap of the electrodes, also when using a new spark plug. Adjust the gap to the correct value if necessary (see Fig. Fig. 9-8).

The spark plug is ready to be installed.

Installing the spark plug

1. Turn the checked spark plug clockwise **by hand** into the spark plug on the engine (see Fig. Fig. 9-7 - ②). Ensure that it is inserted without tilting, not to damage the thread.
2. Tighten the spark plug using the spark plug wrench supplied.
3. Press the spark plug connector firmly onto the spark plug.

The spark plug has been serviced in an orderly manner.

The generator is ready to use.

9.6 Starter battery

9.6.1 Charging the battery

The battery can discharge after a longer immobilisation period or excessive power consumption in the control circuit of the generator.

Always remove the starter battery before charging (see Chapter 9.6.2). Exactly observe the handling instructions provided by the battery manufacturer. Wrong charging destroys the battery!



WARNING!

There is a risk of explosion and fire in the case of inappropriate handling and spark development when working with the battery.

Danger from spraying sulphuric acid. Danger of suffering severe even deadly burns and chemical burns. Danger of being blinded.



- ▶ Never lay electrically conductive parts on the starter battery.
- ▶ Flames, sparks, an open light and smoking are prohibited.
- ▶ Avoid sparks when handling cables and electrical devices, as well as electrostatic discharge.
- ▶ Avoid short-circuits.
- ▶ Wear acid-resistant protective clothing.



WARNING!

Escaping corrosive acid fumes or sulphuric acid during and after the charging process. A risk of suffering severe or even deadly burns.

- ▶ Only work with acid-resistant protective equipment.
- ▶ Clean surfaces covered in acid immediately using adequate amounts of water.
- ▶ Only charge the starter battery in a well ventilated environment.

Requirements

- ✓ The starter battery is removed.
- ✓ For charging the starter battery is located at a well ventilated location.

Charging the battery

1. Attach the starter battery according to the regulations from the battery and charger manufacturers.
2. Set a suitable charge current for the charger if necessary.
3. Switch off the charger of expiry of the charging time.
4. Disconnect the starter battery from the charger.
5. Allow the starter battery to rest for about thirty minutes.

6. Install the starter battery again in the generator (see Chapter 9.6.2).

The starter battery is charged.

If the generator cannot be started after fully charging the battery, there is a defect in the starter power circuit of the generator. Contact your service partner.



NOTICE!

The starter battery from the factory is maintenance-free throughout its entire service life.

- ▶ Never try to open the battery - risk of destruction.

9.6.2 Replacing the battery

Proceed as follows to change the starter battery.

Requirements

Remove the starter battery

- ✓ The generator is turned off.

1. Loosen the six screws to remove the ventilation grille Fig. 6-2 **9** .
*You now have access to the starter battery under the cover Fig. 9-9 - **1** .*
2. Remove the retaining strap Fig. 9-9 - **2** .
3. Remove the cover Fig. 9-9 - **1** from the battery.
4. Carefully pull the starter battery out of its compartment to expose the battery connections.
5. FIRST loosen the black cable Fig. 9-9 - **3** from the negative pole of the battery.
6. LATER loosen the red cable Fig. 9-9 - **4** from the positive pole of the battery.
7. Pull the red pole protection cap off the positive pole of the battery and THEN loosen the red cable from the battery.
8. Fully remove the battery from the battery compartment.
9. Loosen the six screws to remove the ventilation grille Fig. 6-2 **9** .

The starter battery is removed.

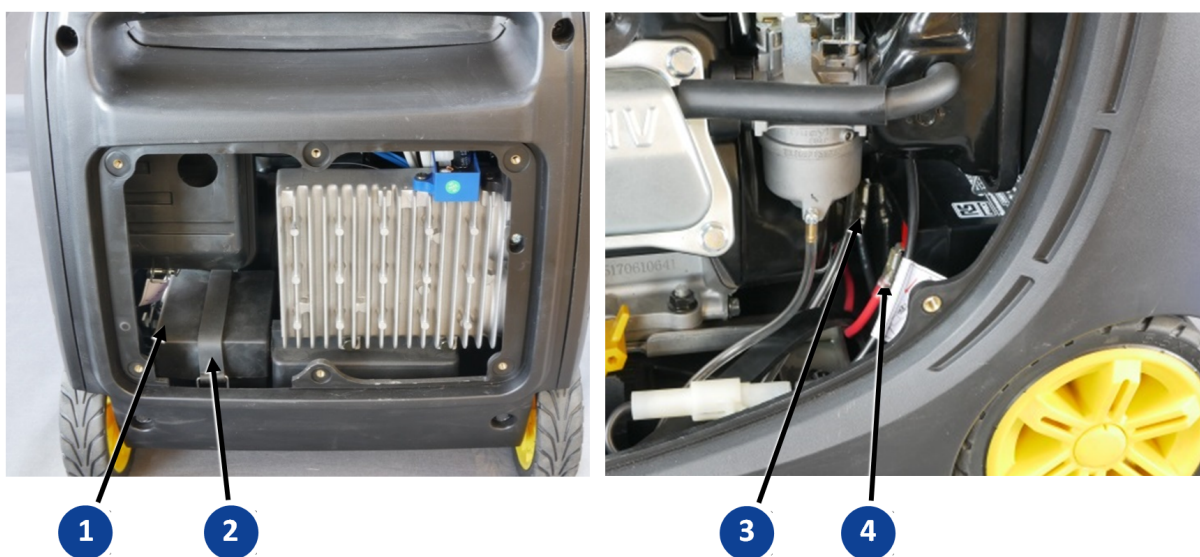

Fig. 9-9 Replacing the starter battery

Installing the starter battery

1. Make ready a new starter battery (Observe the instructions from the battery manufacturer).
2. FIRST fasten the red cable Fig. 9-9 - ④ to the positive pole of the battery.
3. THEN fasten the black cable Fig. 9-9 - ③ to the negative pole of the battery.
4. Place the starter battery in the battery compartment.
5. Put the cover Fig. 9-9 - ① over the battery.
6. Fasten the battery with the retaining strap Fig. 9-9 - ②.
- 7.

The starter battery has been replaced. The generator can now be started.

9.7 Cleaning the spark screen

The spark screen prevents escaping of glowing exhaust particles and is located right next to the exhaust outlet. It must be disassembled every 100 operating hours and cleaned. The spark screen must be replaced if it is strongly soiled or damaged.

Proceed as follows to service the spark screen.

One has the required tool

Requirements

- a small slotted-head screwdriver
 - Wire brush
- ✓ The generator is switched off.
 - ✓ The engine and particularly the exhaust system have cooled down.

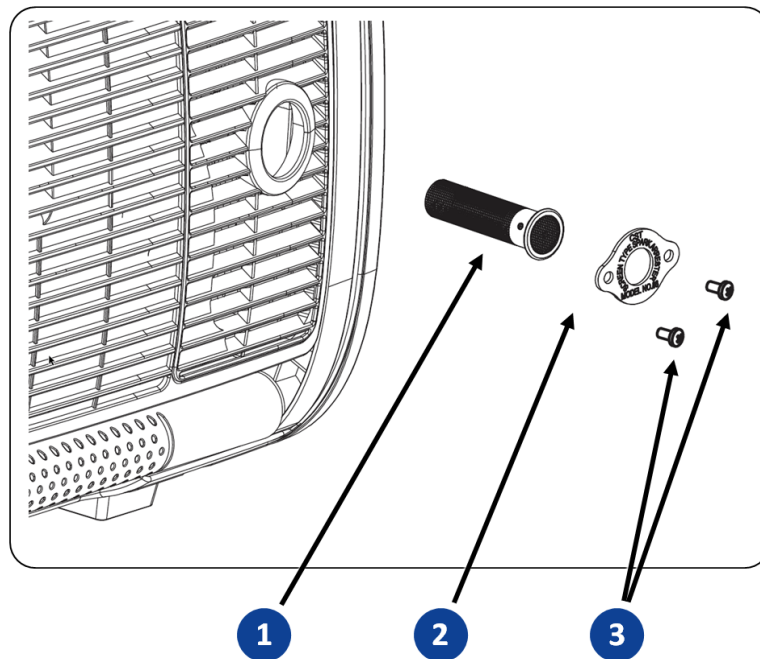

Fig. 9-10 Spark screen

Servicing the spark screen

1. Loosen both screws Fig. 9-10 - ③ on the spark screen.
2. Remove the fixing plate Fig. 9-10 - ② on the spark screen.
3. Loosen the spark screen with the aid of a small slotted-head screwdriver Fig. 9-10 - ① from the exhaust gas outlet and pull it out completely.
The spark screen is removed.
4. Assess the condition of the spark screen and replace it if it is damaged.

5. If the spark screen does not need replacing, clean it thoroughly with the aid of the wire brush.
6. Perform steps 1 to 3 in reverse order in order to fasten the spark screen again.

The spark screen is serviced. The generator can be put into operation again.

9.8 Cleaning the power generator

Keep your generators clean and dry to ensure safe use at all times and a long service life. Never expose your generators to extreme weather conditions, environments with heavy dust and dirt, moisture or aggressive vapours.



DANGER!

Danger of current flow if water enters.

Mortal danger from electrocution

- ▶ Never clean the device during active operation.
- ▶ Never clean the device under running water or by using a high pressure cleaner.

NOTICE!

Never use a garden hose to clean the generators. Water can get inside through the cooling slots and damage the device.

Proceed as follows to clean the generators:

- Use a soft brush to remove any dirt or oil.
- Use a damp cloth to clean the outside of the device
- Inspect all ventilation and cooling slots to ensure that they are clean and free.
- Use a clean cloth or an air compressor (pressure must not exceed 1.7 kPa / bar) to thoroughly dry the device.

10 Storage

It is important to store the device at a suitable storage location as soon as your generator is no longer being used.

- The storage location must be roofed and must not be subjected to standing water, aggressive vapours or soiling as well as major accumulation of dust.
- Protect your device with a cover made out of breathable material.
- Ensure that the storage temperature and air humidity lie within the specified limits (see Technical data).



Due to the limited shelf life of the different operating fluids, it is important for de-commissioning for more than one month that additional measures for storage are taken. While doing this observe the instructions given in the attached operating and maintenance instructions from the engine manufacturer.

11 Disposal

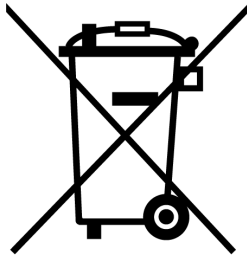

Your device, which is an electrical or electronic device, is subject to European Directive 2012/19/EU (“WEEE directive”) which is implemented in Germany in national law through the decree regulating the use of dangerous substances in electrical and electronic equipment (ElektroStoffV). This regulates disposal and use of recycling waste electrical equipment. The adjacent icon with a crossed-out wastebasket on your device states that it must not be disposed of in the household waste at the end of its service life.

As a private end-user (a so-called b2c customer) there are free collecting points (recycling centre) near you for electrical equipment as well as possible also other collection points available for reuse of devices. The addresses can be obtained from your city or communal authority. In as far as the old electrical and electronic equipment contains personal data, you are responsible yourself for its deletion before giving it back.

Pure b2b devices (devices which, for appropriate use, or exclusively are only used the commercial area) must not be disposed of over public collecting points in Germany and further EU countries. Speak to your authorised ENDRESS generator dealer about handing back your recycling waste electrical equipment. The dealer is also your point of contact for any differing regulations on the respective country of deployment. There are also possible agreements in the purchase contract to observe.

Please observe the pertinent environmental protection regulations when disposing of the old oil. We recommend bringing the oil in a closed container to an old oil collection centre for disposal. Never put used engine oil in the domestic waste. Storage or introduction of old oil into nature is associated with very high fines.

An inappropriately disposed of battery can greatly damage the environment. Give back your old battery directly free of charge to your dealer when purchasing a new one.

Always observe the valid local regulations and laws concerning correct disposal of all old parts and operating materials. Please contact your ENDRESS service partner for a replacement.

12 Troubleshooting

The following table is an aid for you to use in a case where faults arise during use. Based on experience a number of malfunctions can already be removed by operating personnel or the possible causes limited. In all other cases contact your service partner as described in the table. The same applies for faults which are not listed in the table.

If a fault cannot be removed using the remedies described, shut down your generator and secure it against further use. Contact your service partner and give him an explanation, not only of the symptoms but also the possible causes which you can already exclude based upon the table. In this way you are supporting the diagnostic process so that the fault can often already be identified over the telephone or through written exchange with our specialists.



NOTICE!

The following table does not make any claims to completeness and does not mention any faults which can be caused by operating error.

- In order to avoid operating errors, please exactly follow the instructions in the existing and delivered documentation.

Malfunction	possible cause	Correction
The engine turns but does not start.	Fuel level too low	Top up with fuel
	The fuel filter is clogged.	Replace the fuel filter.
	The fuel is unusable due to overaged	Carburettor cleaning, clean the fuel tank and replace the fuel
	Spark plug connector detached	Firmly put the spark plug connector in place again
	The spark plug is very dirty or defective	Clean the spark plug and adjust or replace it
	Engine oil level too low (oil lack automatic switch-off)	Bring the engine oil level up to the maximum
The engine does not rotate	Insufficient compression	Contact your service partner
	The starter battery is discharged or defective (only for electrical starting)	Clean a corroded battery pole Check the starter battery and charge it or replace it
	Starter defective	Replace the starter
	Engine mechanically blocked (also for starting by hand)	Contact your service partner

Malfunction	possible cause	Correction
The engine starts but stops again shortly afterwards	Fuel level too low	Top up with fuel
	The fuel filter is clogged.	Replace the fuel filter.
	Engine oil level too low (oil lack automatic switch-off)	Bring the engine oil level up to the maximum
	Spark plug connector detached	Firmly put the spark plug connector in place again
	Tank ventilation (tank cover) blocked	Clean ventilation holes
The generator is running but there is no (output) voltage at the socket	Overload protection triggered (operating status display lights up red)	Connect up a piece of power consuming equipment with a low output
	The alternator or cabling is defective	Contact your service partner
	The engine speed regulator is wrongly adjusted or defective	Contact your service partner
The generator is running but the output voltage is outside of tolerance	The electronic voltage regulator is wrongly adjusted or defective	Contact your service partner
	The load of the attached power consuming equipment is too high	Connect up a piece of power consuming equipment with a low output
The power output remains significantly below the nominal output	Operation under extreme climatic conditions	Adapt to the climatic conditions or stop the generator
	The generator has been poorly serviced	Perform maintenance work
	The generator has reached its wear limit	Contact your service partner
The engine smokes	The engine oil level is too high	Draining off excess engine oil
	The air filter insert (paper) is dirty or contaminated with oil	Clean the air filter insert or replace it
	The air filter insert (foam) is dirty	Clean the air filter insert and re-oil it
The generator is running at a high speed and with strong voltage fluctuations	The engine is still in the warm up phase	Wait until the engine has reached its operating temperature
	The carburettor is wrongly adjusted or defective	Contact your service partner
	The engine speed regulator is defective	Contact your service partner

Tab. 12-1 Troubleshooting

Please contact our customer service for further fault diagnosis as well as procurement of original spare parts and wear parts at

Tel. +49-(0)-7123-9737-44

service@endress-stromerzeuger.de or

www.endressparts.com (see Chapter 14)

13 Technical data

The following table contains the technical data for your generator.

Name	Value	Unit
ESE 3000 i		
Type of alternator	Inverter	
Maximum output [[LTP]	3.300	[W]
Continuous output [PRP]	3.000	[W]
Nominal output factor	1.0	[cosφ]
Nominal frequency	50	[Hz]
Nominal speed	3.800	[min ⁻¹]
Nominal voltage ~1	230	[V]
Nominal current ~1	13	[A]
DC output (battery charging)	12 / 8.3	[V] / [A]
USN output	5 / 2.1	[V] / [A]
Weight (ready for use)	41	[kg]
Drive motor	Single cylinder 4-stroke OHC,	
Displacement	171	[cm ³]
Cooling systems	air-cooled	
Engine oil amount	0.6	[l]
Tank capacity	6.8	[l]
Fuel consumption (at a 75% load) ¹⁾	1.3	[l/h]
Running time (at 75% load) about ⁽¹⁾	5	[l/h]
Dimensions L x B x H	588 x 442 x 452	[mm]
Noise pressure level at the workplace L _{pA} ²⁾	85	[db (A)]
Sound pressure level at a distance of 7m L _{pA} ³⁾	68	[db (A)]
Sound power level L _{WA} ³⁾	93	[db (A)]
Alternator, system of protection	IP 23	
¹⁾ An average value dependent upon the operating conditions and therefore not binding ²⁾ Measured at a distance of 1 m and a height of 1.6 m in accordance with ISO 3744 (Part 10) ³⁾ Measured in accordance with ISO 3744 (Part 10)		

Tab. 13-1 Generator technical data

14 Replacement parts

Maintenance and replacement parts can be obtained quickly and easily from your responsible ENDRESS service partner or ENDRESS dealer. You can alternatively obtain support from our central customer service

by telephone: +49 (0) 71239737-44

by email: service@endress-stromerzeuger.de

Have the item and serial number of your device ready for identification.

As a registered user you can obtain rapid and uncomplicated access to a range of services over our home page to obtain suitable original spare parts for maintenance and repair work. Using your internet browser please go to

<https://endressparts.com>

and click on the area “Documentation and replacement parts“.

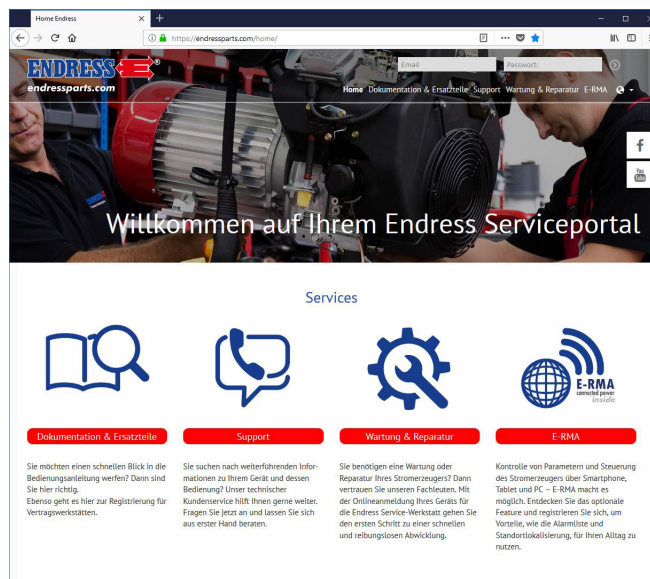
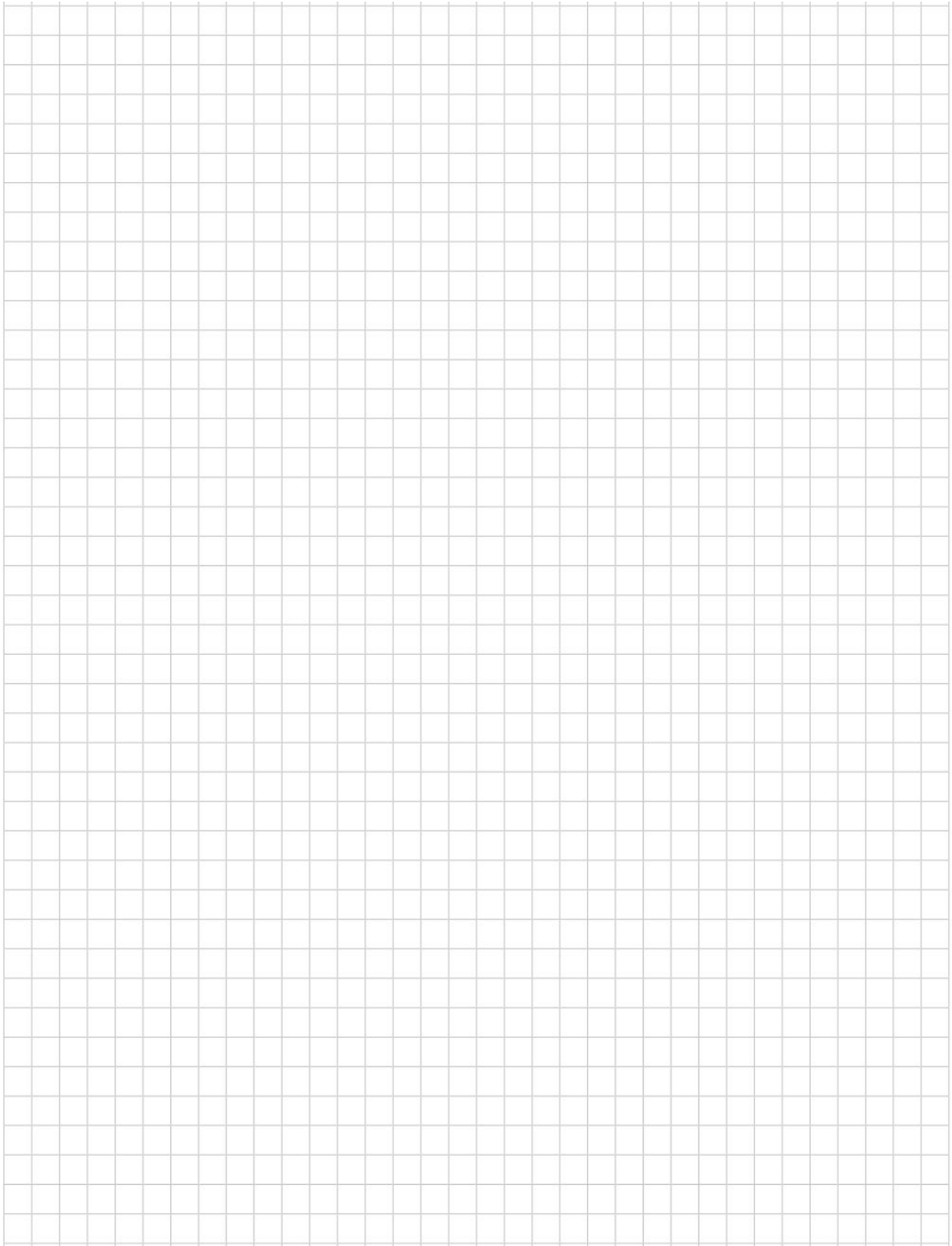
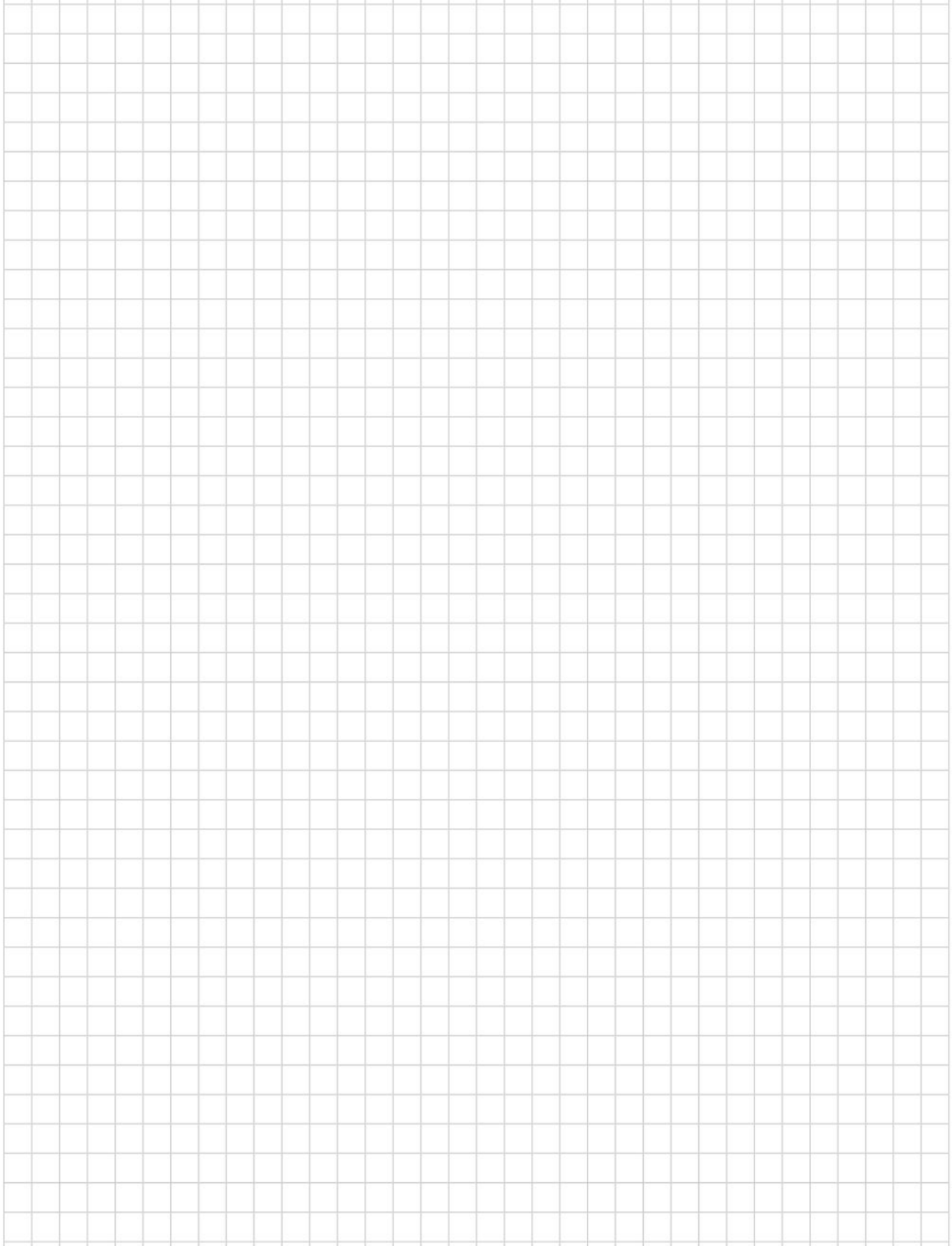

Fig. 14-1 Spare parts over endressparts.com

NOTES



NOTES



Keyword index**A**

Air filter 26

B

Battery charge socket 27

Battery charging cable 11

C

Cable pull starter 25

Carrying handle 29

Choke pull 25

Control panel 25

Control side 24

Customer service 59

D

DIN ISO 3864 6

E

ECO-mode economy circuit 27

Electrical safety 23

energy supply company 9

Engine starter switch 27

evaluated 16

Exhaust gas outlet 26

Exhaust gas side 24

Exhaust gases 18 31

F

Filling funnel 11

Fuel quality 12

Fuel valve 25

fuel valve 31

H

Home page 59

I

Imprint 2

included in delivery 11

L

label 12 12

M

Maintenance flap 26

Maintenance page 24

misuses 9

Multi-functional display 27

N

Noise emissions 13

O

Oil dipstick 26

Oil drain screw 26

Oil filling screw 26

operating manual 7

Operating personnel 16 21

Operating status indicator 27

Operational indicator light 27

P

Potential equalisation device 27

Potential equalization device 23

R

refuel 30

S

safety instructions 14

Safety switch 27

Safety symbols 14

Screwdriver 11

sockets

Schuko 27

Spark plug connector 26

Spark plug wrench 11

Standards

DIN EN ISO 12100 16

DIN EN ISO 8528-13 16

DIN VDE 82079-1 6

ISO 3864 16

ISO 7010 14

standards

DIN EN 60204 16

Starting 31

Suction side 24

T

Tank capacity 12

Tank cover 25

Tank ventilation 25

the standards

VDE 100, Part 551 8

Transport grip 25

Transport wheels 25

Turning off 33

Type plate 12

U

under the operator's obligations 23

USB charge socket 27

W

Warning lights 27

Warning notices 16

WEEE directive 53



**Elektrogerätebau GmbH
Neckartenzlinger Str. 39
D-72658 Bempflingen, Germany**

Tel: +49 (0) 7123 /9737-0

Fax: +49 (0) 7123 /9737-50

Email: info@endress-stromerzeuger.de

www: www.endress-stromerzeuger.de

© 2019, ENDRESS Elektrogerätebau GmbH